

67ft Crawler Boom

PERFORMANCE*

Working Height	20.05 m
Platform Height	18.05 m
Working Outreach	9.85 m
Up and Over Height	8.20 m
Swing (non-continuous)	360°
Jib - Overall Length	1.68 m
Jib - Range of Articulation (+/-)	89° (+0/-89°)
Platform Capacity (unrestricted)	230 kg
Platform Size	0.69 m x 1.34 m
Stowed Width	1.48 m
Machine Weight*	2,940 kg
Gradeability	28%
Maximum Operating Slope	16°
Maximum Approach/Depart Angles	20°
Width of Undercarriage (retracted/extended)	0.79 m/1.09 m

*Certain options or country standards may increase weight and/or dimensions.

STANDARD SPECIFICATIONS*

Power Source

Petrol	Petrol Engine Honda iGX440 11 kW AC Electric Motor 230V, 50 Hz 2.2 kW
Diesel	Kubota Z602-E 10.8 kW (14.5 hp) AC Electric Motor 230V, 50 Hz 2.2 kW
Battery	100 AH, 72V Electric Engine with Lithium Battery Package, Including Battery Charger

Tyres

- Low Profile Non-marking Rubber Tracks 1.46 m x 0.2 m x 0.35 m

STANDARD FEATURES*

- SkyGuard® Enhanced Control Panel Protection
- 0.69 m x 1.34 m Aluminium Two-person Platform
- Slide Bar Rear Entry
- Footswitch
- Full Proportional Control
- Articulating Jib
- Powered Platform Rotator (124°)
- Remote Control (Via Cable to Platform)
- Full Remote Control of Drive and Stabilization
- Multilingual LCD Display on Platform Console
- Platform Console Position Sensor and Lock
- Envelope Management Load Sensing System
- Platform Designed for Ease of Removal/Changeover
- 6.5 mm Air Line to Platform
- Engine Protection
- Rubber Outrigger Pads
- Cylinder Rod Protection on Outriggers
- Automatic Cut-out When Out of Level
- Powered Track Extension/Retraction
- 360° Non-continuous Turntable Rotation
- Turntable Alignment Sensor and Gauge
- Three Emergency Descent Systems
- Electro-hydraulic Controls
- Full Pressure Hydraulic Controls
- 2nd Drive Speed (high)
- Lifting/Tie-down Points
- Forklift Pockets

ACCESSORIES & OPTIONS

- AC Outlet to Platform, Including ELCB
- Fire Extinguisher



67ft Crawler Boom

Dimensions

All dimensions are approximate.

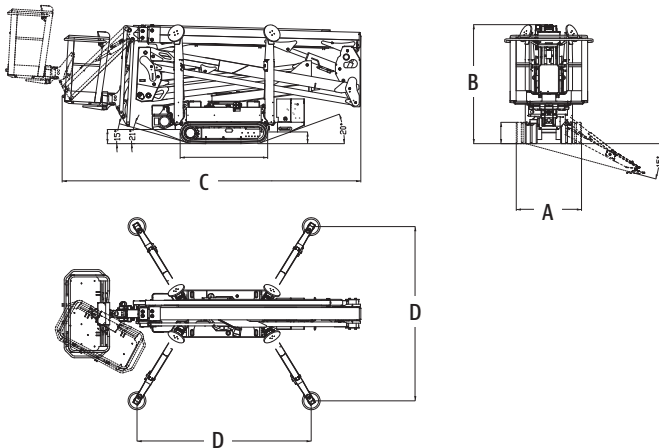

- A. Stowed Width (without platform): 0.80 m
- B. Stowed Height (on tracks): 1.99 m
- C. Stowed Length (on tracks): 5.00 m
- D. Outrigger Footprint: 2.92 m x 2.93 m

Reach Diagram

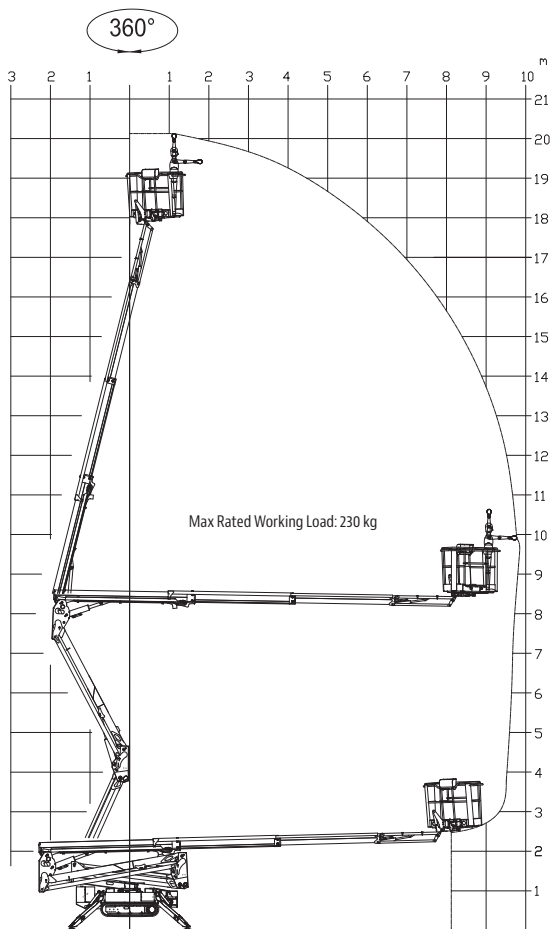

Machine specifications are approximate and are subject to change without notice by manufacture and brand type.