

S2255RT

ROUGH TERRAIN SCISSOR LIFT



- Diesel-powered rough terrain scissor lift
- Large roll-out deck extension
- Automatic self-levelling stabilisers
- Powerful 4x4 drive
- Ideal for construction applications in constricted areas

 **snorkel**
www.snorkellifts.com

ROUGH TERRAIN SCISSOR LIFT

S2255RT

DIMENSIONS S2255RT

Max. working height	8.5m
Max. platform height (A)	6.5m
Platform size	2.73m x 1.4m
Deck extension length	1.2m
Overall width (B)	1.45m
Overall length (C)	3.3m
Stowed height (D)	2.35m
Ground clearance	260mm
Guardrail height	1.1m
Toeboard height	150mm

PERFORMANCE

Platform capacity (SWL)	420kg
Max. wind speed	12.5m/s
Max. drive speed (stowed)	5.2km/h
Max. drive speed (elevated)	0.66km/h
Gradeability	35%
Wheelbase	2m
Inside turning radius	2.5m
Outside turning radius	4.75m
Exit/entry angle	20°
Tyres	23" x 8.9" x 12 poly filled
Drive system	4 wheel drive

POWER

Power source	Kubota diesel engine
--------------	----------------------

WEIGHT

Gross weight	2,360kg
--------------	---------

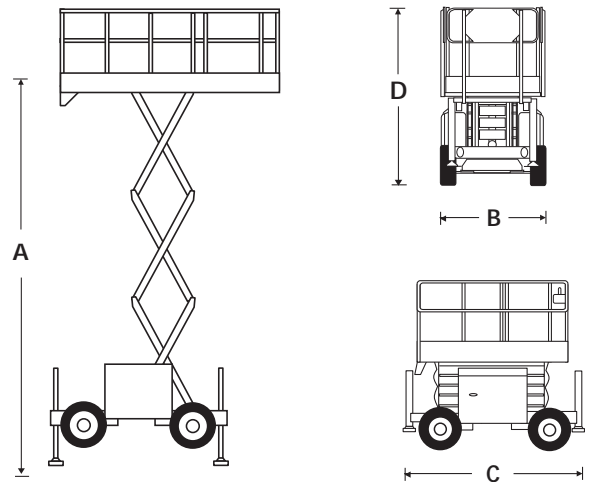

STANDARD FEATURES

- Independent articulating rear axles
- 1.2m roll-out deck extension
- Automatic self levelling stabilisers
- Easy access maintenance modules
- Driveable at full height
- Diesel engine
- 4 wheel drive

OPTIONS

- 24V DC power
- Dual power – diesel/battery
- Non-marking tyres
- Lanyard attachments
- Concrete formwork deck

TURNING RADIUS

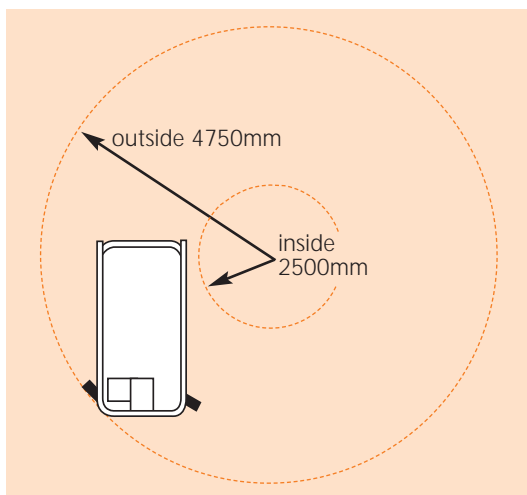

snorkel www.snorkellifts.com

2/26 Redfern Street,
Wetherill Park,
NSW 2164, Australia
t: +61 1300 900 700
e: sales.au@snorkellifts.com